

GL20X01CL

Glove Dispenser - Double



DESCRIPTION

ORIGIN™ Glove Box Dispenser – Double, Clear
Versatile | Visible | Made in the USA

Holds two boxes of gloves for quick access in medical, lab, or food service environments.

Two-way keyholes allow vertical or horizontal mounting.

Crafted from crystal-clear PETG plastic for superior visibility and easy glove level monitoring.

Efficient, hygienic, and proudly made in the USA—order now and optimize your glove storage!

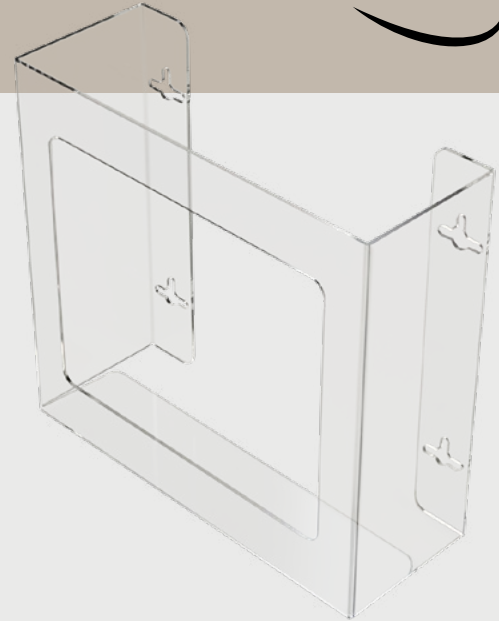

TECHNICAL DATA

Dispenses	
Main Section	Boxes of gloves up to 10.50"W x 9.90"H x 3.75"D

Specifications	
Overall Dimensions	10.70"W x 10.00"H x 3.95"D (27.2 cm x 25.4 cm x 10.0 cm)
Weight	0.9 lbs (0.4 kg) – approx.
Shipping Quantity	6 ea.
Shipping Dimensions	16.00"W x 12.00"H x 12.00"D (40.6 cm x 30.5 cm x 30.5 cm)
Shipping Weight	8.0 lbs (3.6 kg) – approx.
Material	Durable Clear PETG

USAGE AREAS

Ideal for use in healthcare, industrial, food service, and any environment where disposable gloves are required for protection and compliance.

ACCESSORIES

- N/A

FEATURES

- ✓ Holds two boxes of gloves.
- ✓ Three-way keyholes for vertical or horizontal wall or surface/pegboard mounting.
- ✓ Made in USA.

MOUNTING SPECIFICATIONS

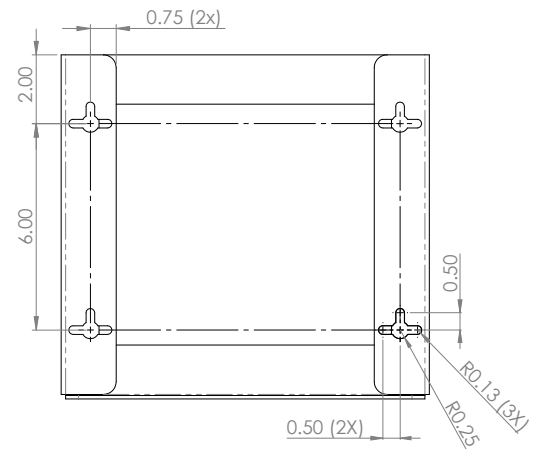

ORIGIN™ DISPENSING SOLUTIONS, LLC

Organization Begins With Us.

P: 360.912.9805

E: CustomerService@OriginDispensingSolutions.com

W: www.OriginDispensingSolutions.com

Product specifications are subject to change without notice.
Accessories and consumable items sold separately.

© 2025 ORIGIN Dispensing Solutions, LLC. All rights reserved.

GL20X01CL-TDS01