

GL20X04BK

Glove Dispenser - Double



DESCRIPTION

ORIGIN™ Glove Box Dispenser – Double, Black Powder-Coated Steel
Durable | Versatile | Made in the USA

Holds two boxes of gloves for efficient, organized access in medical, lab, food service, or industrial environments.

Mounts vertically or horizontally with two-way keyholes for flexible installation.

Constructed from black powder-coated steel—strong, sleek, and built for daily use.

Proudly Made in the USA – a hygienic, space-saving storage solution with a modern, professional finish.

Streamline your glove dispensing with durable, dependable design—order today!

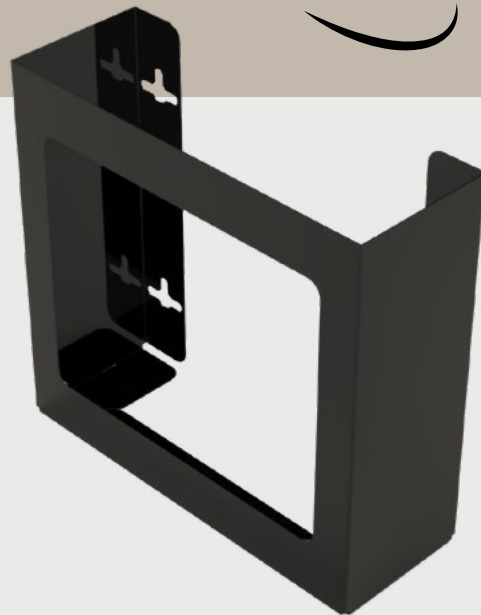

TECHNICAL DATA

Dispenses	
Main Section	Boxes of gloves up to 10.50"W x 9.90"H x 3.75"D

Specifications	
Overall Dimensions	10.60"W x 9.95"H x 3.85"D (26.9 cm x 25.3 cm x 9.8 cm)
Weight	1.6 lbs (0.7 kg) – approx.
Shipping Quantity	6 ea.
Shipping Dimensions	16.00"W x 12.00"H x 12.00"D (40.6 cm x 30.5 cm x 30.5 cm)
Shipping Weight	12.0 lbs (5.4 kg) – approx.
Material	Durable Black Powder-Coated Steel

USAGE AREAS

Ideal for use in healthcare, industrial, food service, and any environment where disposable gloves are required for protection and compliance.

ACCESSORIES

- N/A

FEATURES

- ✓ Holds two boxes of gloves.
- ✓ Two-way keyholes for vertical or horizontal wall or surface mounting.
- ✓ Made in USA.

MOUNTING SPECIFICATIONS

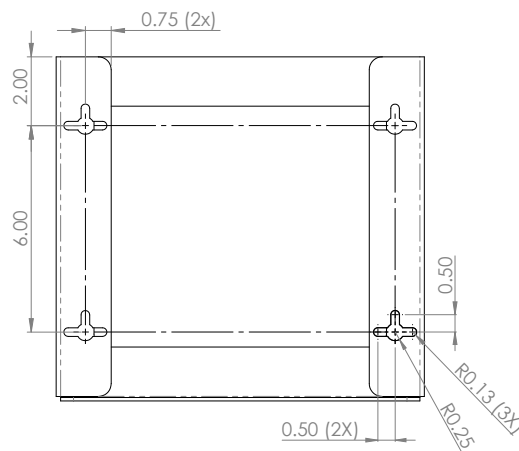

ORIGIN™ DISPENSING SOLUTIONS, LLC

Organization Begins With Us.

P: 360.912.9805

E: CustomerService@OriginDispensingSolutions.com

W: www.OriginDispensingSolutions.com

Product specifications are subject to change without notice.
Accessories and consumable items sold separately.

© 2025 ORIGIN Dispensing Solutions, LLC. All rights reserved.

GL20X04BK-TDS01