

GL24X02BG



Wall-Backed Glove Box Dispenser - Double

DESCRIPTION

ORIGIN™ Wall-Backed Glove Box Dispenser – Double, Quartz Beige ABS
Durable | Lightweight | Made in the USA

A functional, space-saving solution for efficient glove access in any healthcare or industrial environment.

This double glove box dispenser is constructed from tough, injection-molded Quartz Beige ABS plastic—designed for wall protection with a solid back panel and support for vertical mounting. Boxes load horizontally for convenience, and the unit is stackable to maximize space.

Easy to clean, impact-resistant, and built for daily use.



TECHNICAL DATA

Dispenses	
Main Section	Boxes of gloves up to 10.25"W x 9.40"H x 3.80"D

Specifications	
Overall Dimensions	10.45"W x 9.50"H x 4.00"D (26.5 cm x 24.1 cm x 10.2 cm)
Weight	1.2 lbs (0.5 kg) – approx.
Shipping Quantity	6 ea.
Shipping Dimensions	16.00"W x 12.00"H x 12.00"D (40.6 cm x 30.5 cm x 30.5 cm)
Shipping Weight	8.0 lbs (3.6 kg) – approx.
Material	Durable Clear PETG

USAGE AREAS

Ideal for use in healthcare, industrial, food service, and any environment where disposable gloves are required for protection and compliance.

ACCESSORIES

- N/A

FEATURES

- ✓ Holds two boxes of gloves.
- ✓ Three-way keyholes for vertical or horizontal wall or surface/pegboard mounting.
- ✓ Made in USA.

MOUNTING SPECIFICATIONS

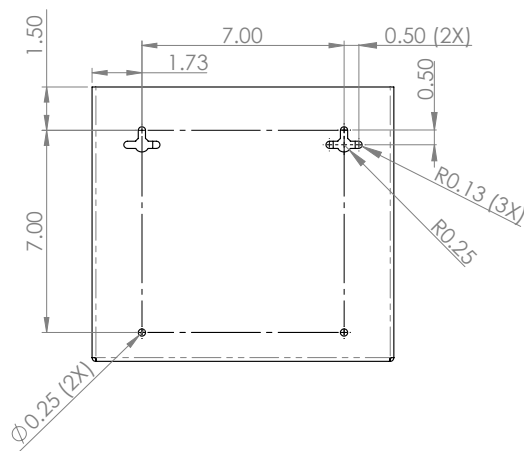

ORIGIN™ DISPENSING SOLUTIONS, LLC

Organization Begins With Us.

P: 360.912.9805

E: CustomerService@OriginDispensingSolutions.com

W: www.OriginDispensingSolutions.com

Product specifications are subject to change without notice.
Accessories and consumable items sold separately.

© 2025 ORIGIN Dispensing Solutions, LLC. All rights reserved.

GL24X02BG-TDS01